

# Ceiling Mount Signs – Viewable 2 Sides

## Product Data Bulletin

### Description:

Aluminum substrate signs printed with UV resistant eco-solvent ink, reinforced with UV, chemical, abrasion, and moisture resistant laminate layer. Double flange is shaped to allow mounting on a drop ceiling by setting the sign between the ceiling tile and the tile track. Recommended for indoor and outdoor business and industrial environments. Service temperature range -40 F to +180 F

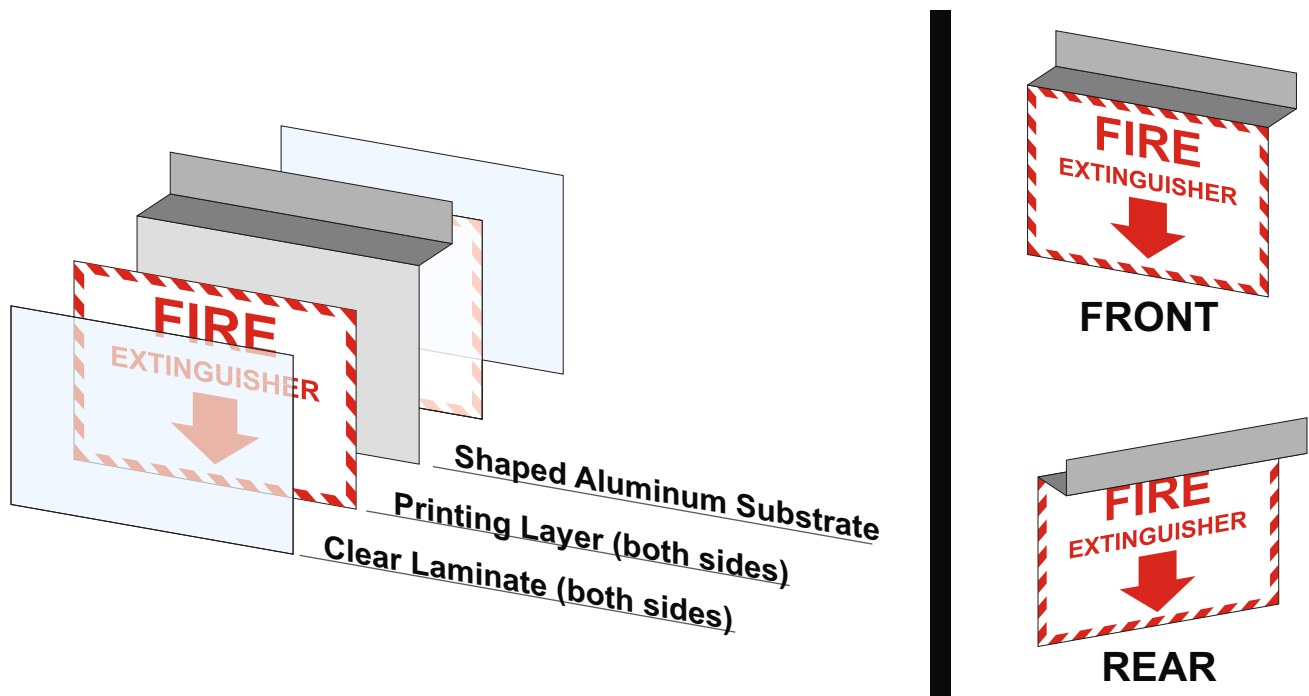

### Specifications:

<b>SUBSTRATE:</b>	0.040" (1mm) aluminum, white enamel coated both sides
<b>PRINTING LAYER:</b>	3.0 mil Vinyl with 1.0 mil permanent acrylic adhesive UV Stable Eco-solvent ink
<b>LAMINATE:</b>	3.0 mil, PVC Film (Optically Clear) <ul style="list-style-type: none"><li>• Scratch Resistant</li><li>• Chemical Resistant</li><li>• UV Resistant</li></ul>
<b>MOUNTING:</b>	Double shaped flange for mounting on drop ceiling
<b>OPTIONS:</b>	Available for additional charge: <ul style="list-style-type: none"><li>• Reflective or Glow-in-the-Dark</li></ul>